

# ETRONIX

## GETTING TO KNOW YOUR TRANSMITTER

### EX4GT Transmitter Specifications

Channels: 2 proportional channels + 1 three-stage switch channel + 1 two-stage-switch channel  
Voltage range: 4.2V-8.4V  
Transmitter frequency: 2.4G (FHSS)  
Modulation: GFSK  
Transmit power: <20dBm  
Range control distance: >120m  
Power supply: 4 cell AA batteries  
Adjust mode: Knob

### EX4GT Receiver Specifications

Channel number: 4 channels (standard PWM output)  
Voltage range: 4-6.5V  
Waterproof level: IP67  
Interface: Futaba, JR  
Size: 33 X 22 X 13mm  
Weight: 5g

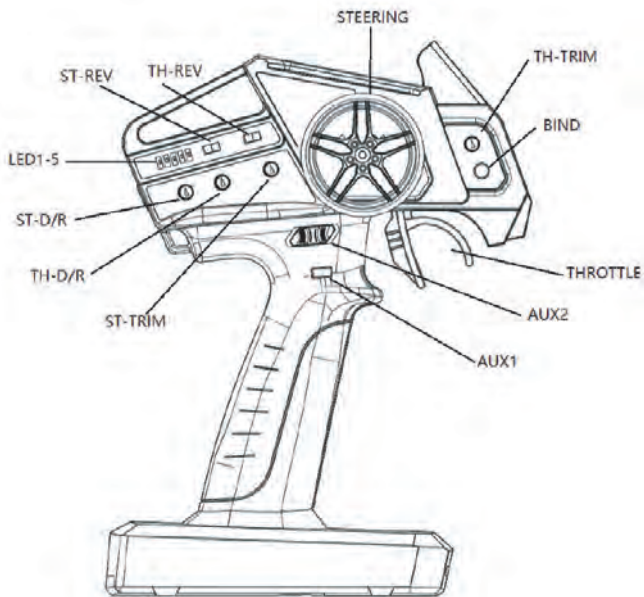

### Installing the transmitter batteries

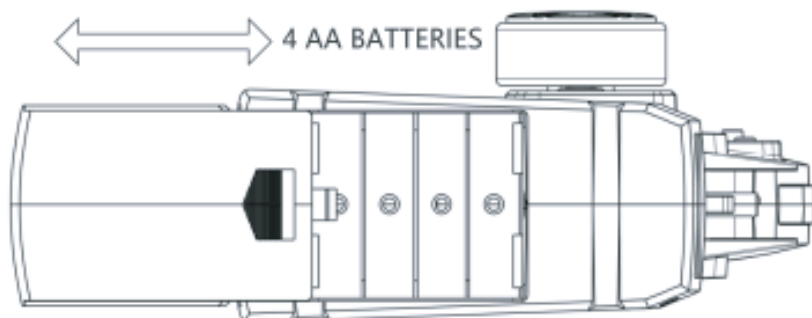

### EX4GT Transmitter Function

EX4GT is a 4 channel transmitter which features 4 channels for proportional steering, proportional throttle, AUX1 button channel and AUX2 3-stage switch channel.

The following functions can all be set:

- Throttle Trim (TH-TRIM)
  - Steering Trim (ST-TRIM)
  - Throttle Dual/Rate (TH-DR)
  - Steering Dual/Rate (ST-DR)
  - Throttle Reverse (TH-REV)
  - Steering Reverse (ST-REV)
  - Throttle Endpoint Adjustment (TH-EPA)
  - Steering Endpoint Adjustment (ST-EPA)
- The transmitter has an LED power display and alarm function, and TRIM, DR, EPA adjustment status display function.

EX4GT receiver function has 4 channels Steering (ST), Throttle (TH), AUX1 and AUX2 along with a FAILSAFE function.

# ETRONIX

## Power display

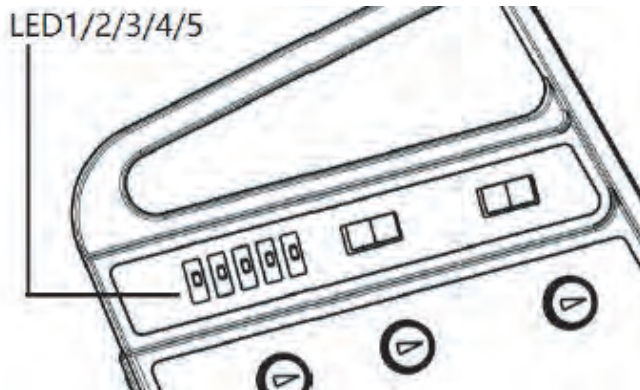

LED1/2/3/4/5 : 100% Power

LED1/2/3/4: 80% Power

LED1/2/3: 60% Power

LED1/2: 40% Power

LED1: 20% Power

### Low voltage alarm

LED1/2/3/4/5

->LED1/2/3/4->LED1/2/3->

LED1/2->LED1->LED1-5 FLASH, cycle loop

## EX4GT Receiver

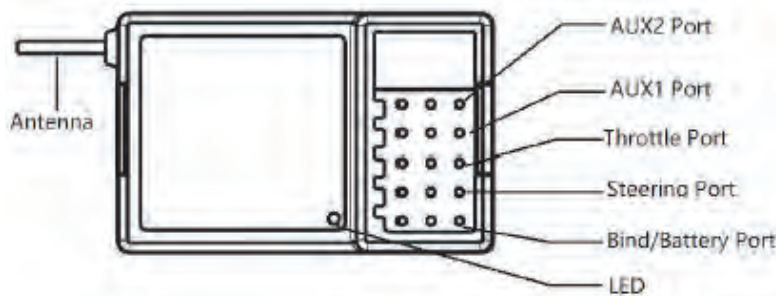

### Binding:

**STEP1:** Plug in the binding wire, then power on. The LED of the receiver will flash rapidly, indicating that it has entered the binding mode and is waiting to bind.

**STEP2:** Press the BIND key of the transmitter, then power on the transmitter. The transmitter will enter the binding mode. LED 1-5 will cycle in turn.

**STEP3:** After binding is successful, the receiver LED will remain on. The transmitter exits the binding mode after 5 seconds and the LEDs display the battery level.

### Receiver LED status:

1. When the receiver receives the correct signal the LED light is always on.
2. After the receiver is turned on, the LED will be off after 1 second, indicating that the receiver has not received a signal from the transmitter. Please check whether the transmitter is turned on, or whether it has been bound.
3. When the LED flashes rapidly, it indicates the receiver has entered the binding mode.
4. If the receiver displays a slow flashing LED it indicates that the receiver is in a disconnected state.

### FAILSAFE:

The ST and TH channels of the receiver both have a FAILSAFE function. The FAILSAFE output of ST and TH can be set as follows:

1. Turn on the transmitter and receiver and make a normal connection.
2. Adjust the transmitter's TH and ST to the position you require when connection is lost and you wish the FAILSAFE to become active.
3. Plug the binding wire into the bind port of the receiver. After the receiver LED flashes 2 times, unplug the binding wire to finish the FAILSAFE setting.

# ETRONIX

## RUNNING YOUR CAR

### 1. TURN ON THE RADIO CONTROLLER

Switch on the power switch on the radio controller. Your radio is bound with your car automatically.

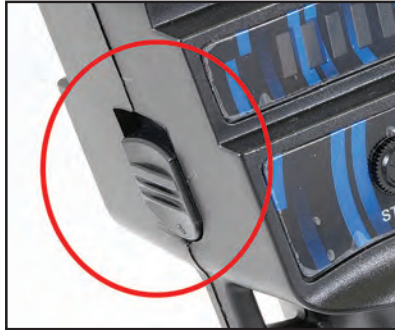

### 2. TURNING ON THE RECEIVER OF YOUR CAR

The ESC Receiver switch is located under the bodyshell of the model. Switch on the ESC/Receiver Switch as shown in the picture.

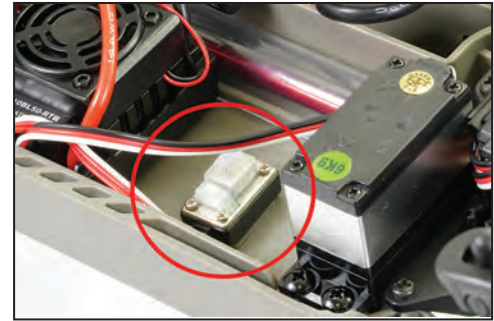

### 3. CHECK STEERING PERFORMANCE

CENTRE

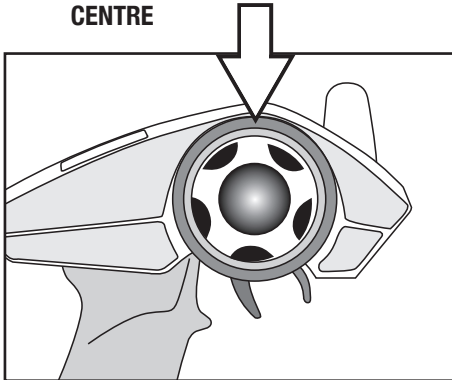

1. To keep the car running straight, keep the steering wheel centered.

TURN RIGHT

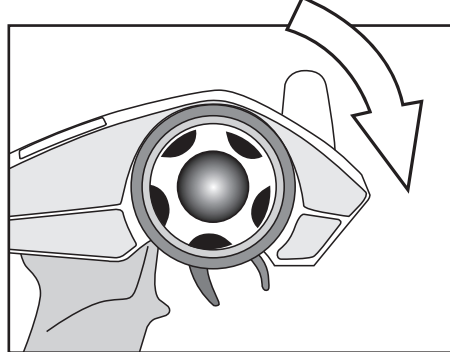

2. Turn the steering wheel to the right to allow the car to right.

TURN LEFT

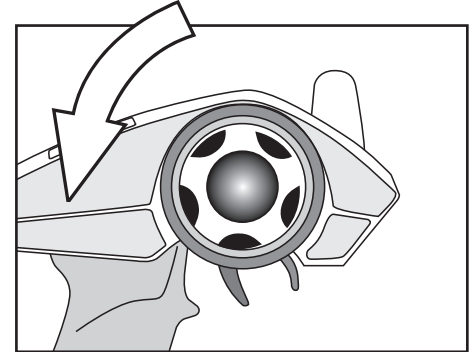

3. Turn the steering wheel to the left to allow the car to turn to the left.

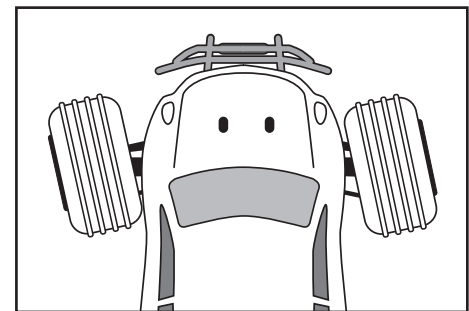
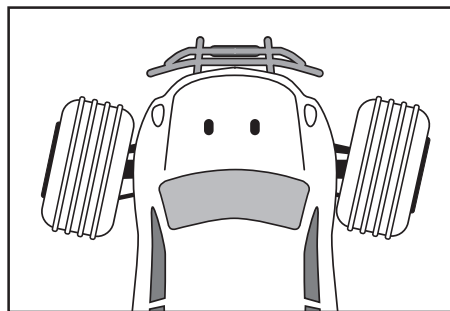
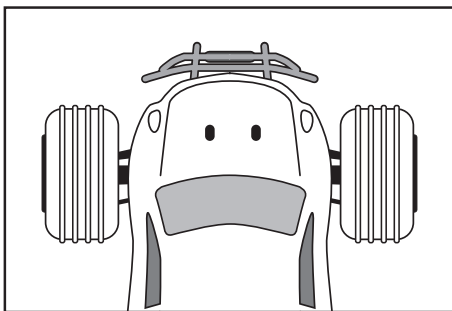

### 4. CHECK TRIGGER RESPONSE

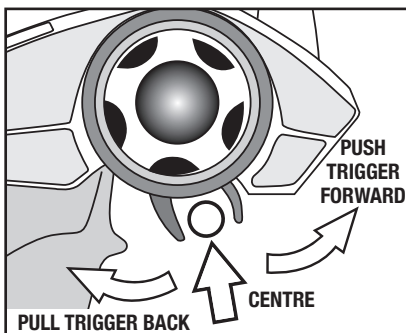

PLEASE NOTE: THE MODEL SWITCHES BETWEEN FORWARD AND REVERSE INSTANTLY FOR SLOW SPEED MANEOUVABILITY. EXCESSIVE USE OF THIS FEATURE CAN CAUSE TRANSMISSION AND ESC DAMAGE.

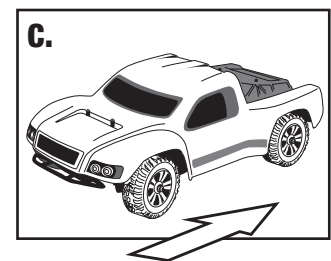
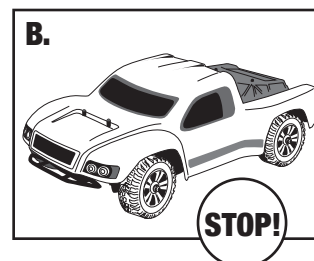
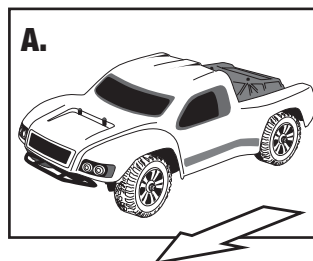

A. Pull the trigger back to accelerate, release it to decelerate.  
 B. To stop running your car, release the trigger to neutral.  
 C. Pushing the trigger forward activates reverse.

# ETRONIX

## RUNNING YOUR CAR

### 5. TUNING THE STEERING TRIM

#### STEERING TRIM KNOB:

The ST-TRIM knob is used to adjust the trim of the steering so that the wheel are centered and the vehicle tracks straight.

When you adjust the ST-TRIM, the LED will display the ST-TRIM value. After the adjustment is completed for 5 seconds, the LED will return to indicate the battery level.

STEERING

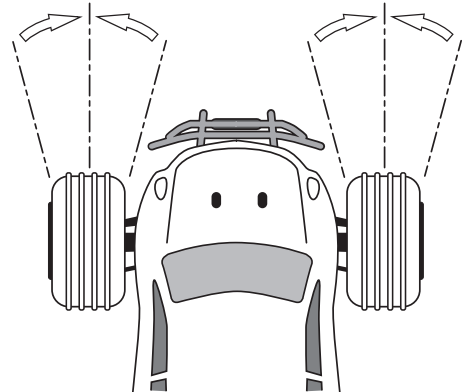
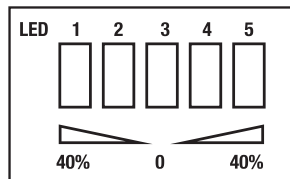

### 6. TUNING THE THROTTLE TRIM

#### THROTTLE TRIM KNOB:

The TH-TRIM knob is used to adjust the throttle trim when the throttle stick is at neutral position. It is typically used to adjust the brakes.

When you adjust the TH-TRIM, the LED will display the TH-TRIM value. After the adjustment is completed for 5 seconds, the LED will return to indicate the battery level.

THROTTLE TRIM

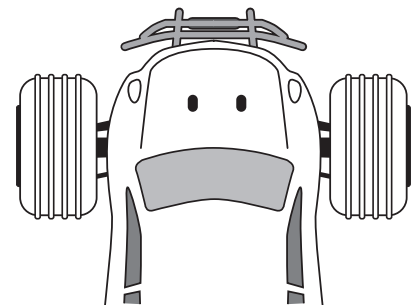
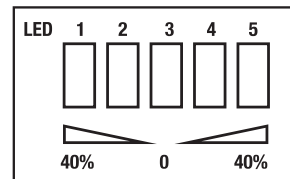

### 7. TO TUNE THE STEERING DUAL RATE CONTROL DIAL

#### STEERING D/R KNOB:

The dial marked ST-DR is for servo travel adjustment.

You should adjust this to give maximum steering without straining the servo.

When rotated fully anticlockwise zero rate is applied.

Turn anti-clockwise to apply dual-rate percentage.

When adjusting the DR, the LED light bar will display the DR value.

After 5 seconds the LED light bar will return to display the battery level.

STEERING D/R

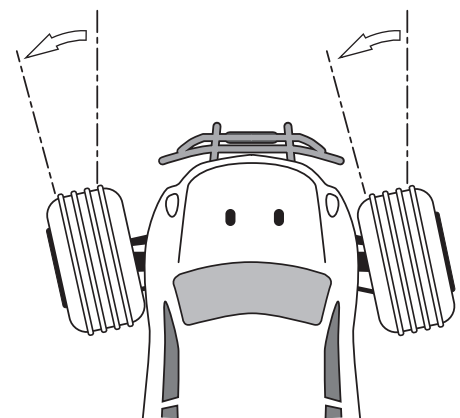
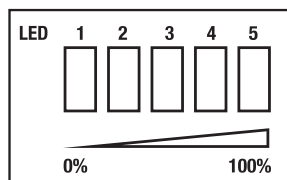

### 8. STEERING/THROTTLE REVERSE

This function is used to adjust each channels direction of movement in relation to it's input .The ST.REV/TH.REV switches are the reverse buttons for CH1 and CH2.

If the switch is up it indicates reverse, down indicates normal.

